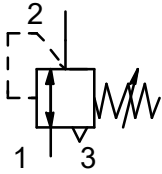
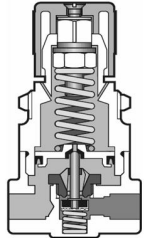
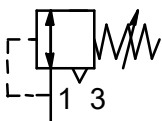

2. témakör: Pneumatikus vezérlések

Nyomáscsökkentő szelep

Nyomáscsökkentő szelep		
------------------------	---	---

Biztonsági nyomáshatároló szelep

Biztonsági nyomáshatároló szelep		
----------------------------------	---	--

Egyenirányító szelep

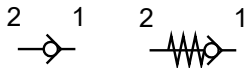
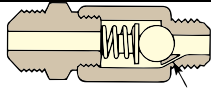
Visszacsapó szelep egyszerű és rugós		
--------------------------------------	---	--

Biztonsági (zuhanásgátló) szelep

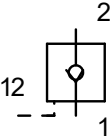
Vezérelt visszacsapó szelep		
-----------------------------	---	--

Kétirányú sebességszabályzó szelep

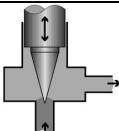
Fojtó szelep		
--------------	---	---

Egyirányú sebességszabályzó szelep

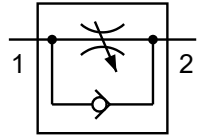
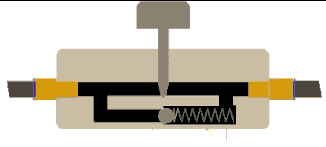
Fojtó-visszacsapó szelep		
--------------------------	---	---

Logikai szelepek

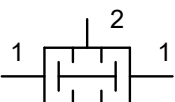
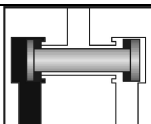
„ÉS” szelep		
-------------	---	---

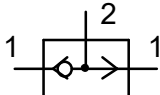
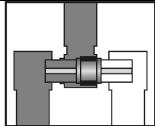
„VAGY” szelep		
---------------	---	---

Gyorsleürítő szelep

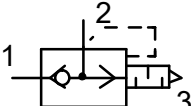
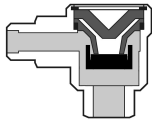
Gyorsleürítő szelep		
---------------------	---	---

Útváltó szelepek

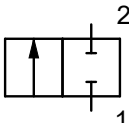
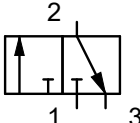
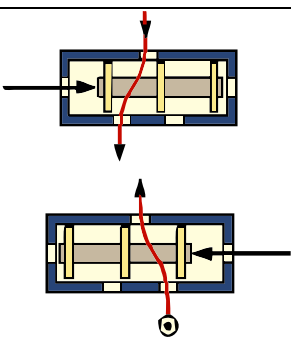
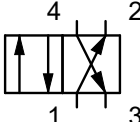
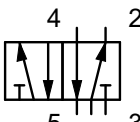
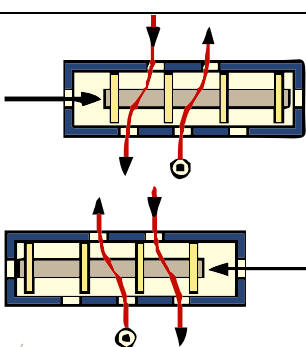
2/2-es szelep		
3/2-es szelep		
4/2-es szelep		
5/2-es szelep		

Útváltó szelepek kiegészítói

Monostabil (rugó-visszatérítéses) (Spring-returned)		
---	---	--

Elővezérelt (szervó) (Piloted)		
-----------------------------------	---	--

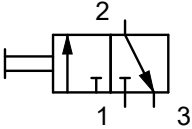
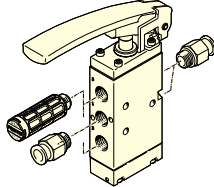
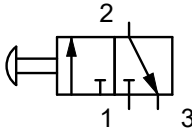
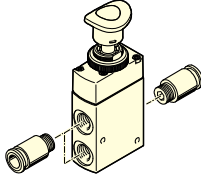
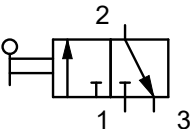
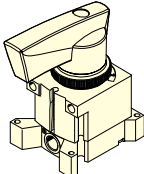
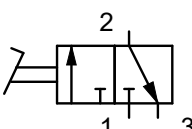
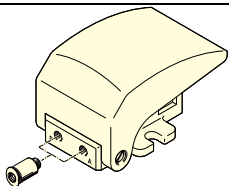

Útváltó szelepek működtetői

Emberi beavatkozással működtetett (Manually) (3/2-es példán)

Általános kézi működtetés		
Nyomógombos		
Kézikaros		
Lábpedálós		

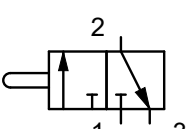
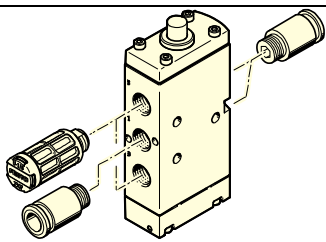
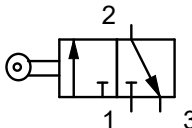
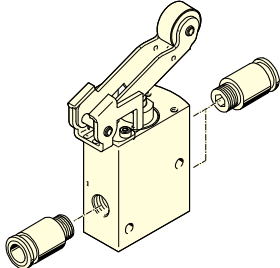
Mechanikus működtetés (Mechanically) (3/2-es példán)

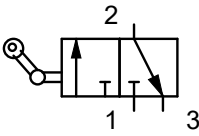
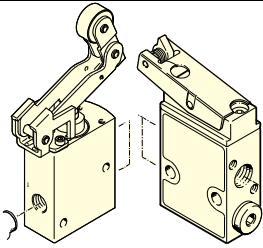
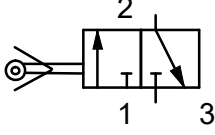
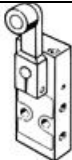
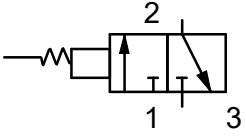
Csapos		
Görgős		

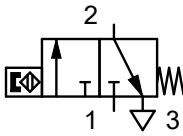
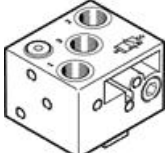
Egyirányban kapcsoló görgős vagy ékes		
Elforduló görgős		
Pálcás (csavarrugóban végződő acélpálca érzékel)		
Mágnes-közelítéskapcsolós (kengyellel a munkahenger külső falára rögzíthető)		

Pneumatikus működtetés

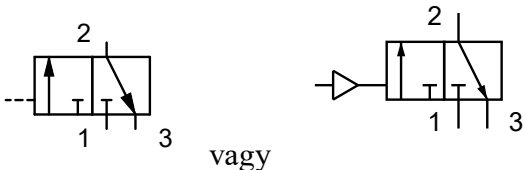
Pneumatikus működtetés	
------------------------	--

Elektromos működtetés

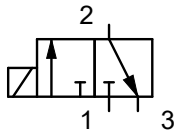
Elektromos működtetés	
-----------------------	--